



PHYLOGENY AND BIOGEOGRAPHY OF TAXUS (TAXACEAE) INFERRED FROM SEQUENCES OF THE INTERNAL TRANSCRIBED SPACER REGION OF NUCLEAR RIBOSOMAL DNA

Author(s): Jianhua Li, Charles C. Davis, Peter Del Tredici and Michael J. Donoghue

Source: *Harvard Papers in Botany*, Vol. 6, No. 1 (July 2001), pp. 267-274

Published by: Harvard University Herbaria

Stable URL: <http://www.jstor.org/stable/41761651>

Accessed: 14-06-2016 15:34 UTC

REFERENCES

Linked references are available on JSTOR for this article:

http://www.jstor.org/stable/41761651?seq=1&cid=pdf-reference#references_tab_contents

You may need to log in to JSTOR to access the linked references.

Your use of the JSTOR archive indicates your acceptance of the Terms & Conditions of Use, available at

<http://about.jstor.org/terms>

JSTOR is a not-for-profit service that helps scholars, researchers, and students discover, use, and build upon a wide range of content in a trusted digital archive. We use information technology and tools to increase productivity and facilitate new forms of scholarship. For more information about JSTOR, please contact support@jstor.org.



Harvard University Herbaria is collaborating with JSTOR to digitize, preserve and extend access to *Harvard Papers in Botany*

PHYLOGENY AND BIOGEOGRAPHY OF *TAXUS* (TAXACEAE) INFERRED FROM SEQUENCES OF THE INTERNAL TRANSCRIBED SPACER REGION OF NUCLEAR RIBOSOMAL DNA

JIANHUA LI,¹ CHARLES C. DAVIS,² PETER DEL TREDICI,¹
AND MICHAEL J. DONOGHUE³

Abstract. Species of *Taxus*, particularly *Taxus baccata*, have long been cultivated as ornamentals in Europe and North America. Ten species of *Taxus* are generally recognized, but phylogenetic relationships among these species remain unclear. We used sequences of the nuclear ribosomal DNA ITS region to infer phylogenetic relationships. Three of the four New World species form a well-supported clade, within which the Pacific coastal species *T. brevifolia* is sister to a clade containing *T. floridana* and *T. globosa* of northwestern Florida and northern Mexico, respectively. *Taxus canadensis*, which is more widely distributed in eastern North America, appears to be more closely related to Old World taxa than to other New World species. This relationship, though weakly supported in our analysis, is consistent with leaf anatomical features. *Taxus chinensis* and *T. mairei* of southeast Asia form a clade, which is sister to a clade containing *T. cuspidata* of Japan and northeastern China, and *T. baccata* of Europe and North Africa. Our ITS phylogeny implies that intercontinental disjunctions in *Taxus* entailed at least two vicariance events: an initial split between the New World *T. floridana*–*T. brevifolia*–*T. globosa* clade and the rest, and a later split separating *T. canadensis* from the Old World species.

Keywords: biogeography, ITS, phylogeny, Taxaceae, *Taxus*.

Species of *Taxus* L. (Taxaceae) are small to medium-sized trees or shrubs; their leaves are arranged on branches in two ranks, and two inconspicuous stomatal bands occur on the underside of the leaf. The seeds are wrapped at least halfway by a conspicuous aril, from orange to deep red in color. The monophyly of *Taxus* is supported by both morphological (Cheng and Fu, 1978; Hart, 1987; Judd et al., 1999) and molecular evidence (Cheng et al., 2000; Wang and Shu, 2000).

Some species of *Taxus*, such as the common yew, *T. baccata* L., have long been cultivated as ornamentals in Europe and North America (Hartzell, 1991). Recently *Taxus* has attracted public attention owing to the discovery of cancer-inhibitory taxol in the bark of the Pacific yew, *T. brevifolia* Nuttall (Wani et al., 1971).

Ten species of *Taxus* are generally recognized, and these are distributed primarily in the Northern Hemisphere (Fig. 1) from as far north as 61° N in Russia to as far south as Sumatra and El Salvador (Farjon, 1998). In the New World, *T. canadensis* Marshall is widely distributed in northeastern North America from Newfoundland to Manitoba and south to

Virginia and Iowa. *Taxus floridana* Nuttall ex Chapman is restricted to small areas in the Appalachian River valley in the panhandle of Florida, and *T. brevifolia* is found along the Pacific coast of North America, including California, Oregon, Washington, British Columbia, and southern Alaska (Price, 1990). *Taxus globosa* Schlecht. occurs from northeastern Mexico to Guatemala and El Salvador (Hartzell, 1991).

In the Old World, *Taxus cuspidata* Sieb. et Zucc. is found in Japan, northern China, and eastern Russia, and *T. baccata* is widely distributed in Europe and North Africa. In Southeast Asia, *T. wallichiana* Zucc. and *T. fuana* Li et Fu occur in the eastern Himalayas, and *T. chinensis* (Pilger) Rehder (= *T. sumatrana*) and *T. mairei* Lemee et Levl. are found in central and southern China; the former species (*T. chinensis*) extends south of the equator to Malaysia.

The taxonomy of *Taxus* has been difficult and controversial, partly because there are few reliable morphological characters for diagnosing species. Pilger (1903) treated all previously described *Taxus* species as subspecies of *T.*

We thank Jack Alexander of the Arnold Arboretum for his assistance in collecting material for this study.

¹Arnold Arboretum of Harvard University, 125 Arborway, Jamaica Plain, Massachusetts 03824, U.S.A.

²Harvard University Herbaria, 22 Divinity Avenue, Cambridge, Massachusetts 02138, U.S.A.

³Department of Ecology and Evolutionary Biology, Yale University, New Haven, Connecticut 06511, U.S.A.

Harvard Papers in Botany, Vol. 6, No. 1, 2001, pp. 267–274.
© President and Fellows of Harvard College, 2001.

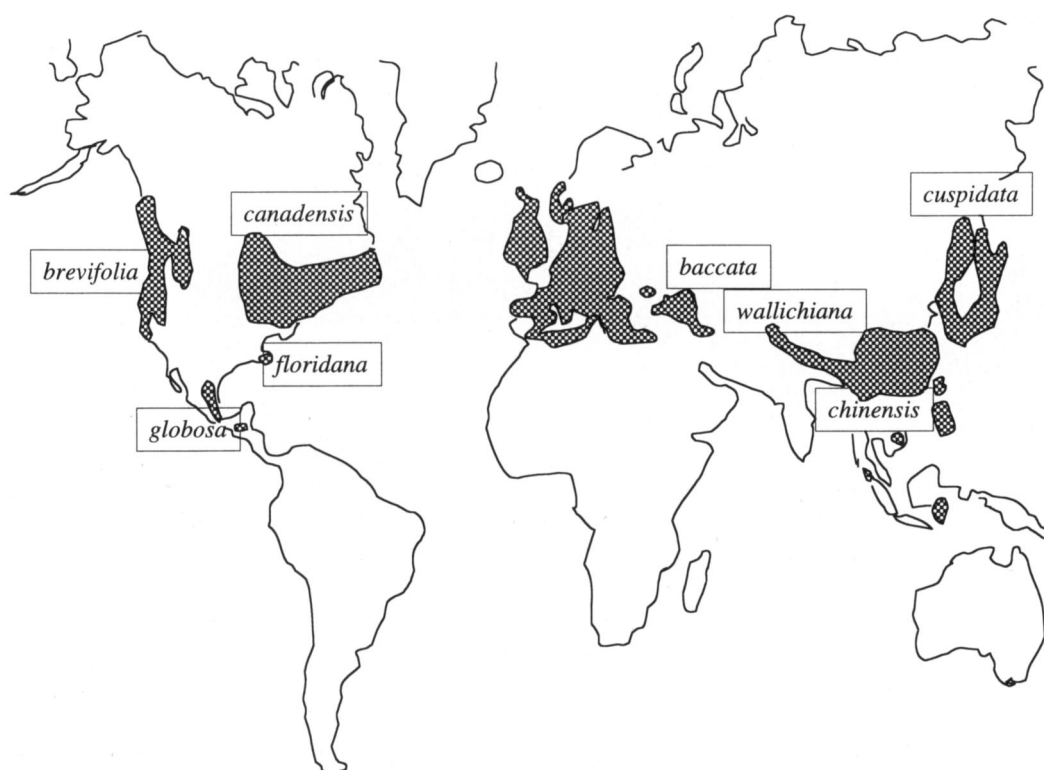

FIGURE 1. The distributions of extant species of *Taxus*.

baccata. This treatment has been adopted by a few authors (Voliotis, 1986; Bolsinger and Jaramillo, 1990), but 10 species are more often accepted (Silba, 1984; Krüssmann, 1985; Welch and Haddow, 1993; Li and Fu, 1997; Farjon, 1998).

Phylogenetic relationships among species of *Taxus* have been implied by various taxonomic treatments but have never been explicitly tested. Both Pilger (1903) and Schneider (1913) treated *T. chinensis* as a variety of *T. cuspidata*, implying a close relationship between these two species. Henry (1906), on the other hand, regarded *T. chinensis* as a variety of *T. baccata*, whereas Florin (1948) considered it a variety of *T. wallichiana*. *Taxus mairei* has been recognized as a variety of either *T. chinensis* (Cheng and Fu, 1978) or *T. wallichiana* (Li and Fu, 1997). Silba (1984) treated *T. floridana* as a variety of *T. canadensis*.

Our objectives were to infer phylogenetic relationships within *Taxus* using sequences of the internal transcribed spacer region of nuclear ribosomal DNA (see Baldwin et al., 1995; Gerandt and Liston, 1999; Kim and Kim, 1999;

Li et al., 2000) and to consider the biogeographic implications of these relationships.

MATERIALS AND METHODS

Taxa

Fifteen samples were included in this study, representing an outgroup, *Pseudotaxus chienii* (Cheng) Cheng, and all species of *Taxus* except for *T. fuana* and *T. wallichiana* (Table 1). For most of the species, two or more individuals were sampled to check intraspecific variation.

Molecular Technique

DNAs were extracted from fresh leaf material using the DNeasy Kit (Qiagen, Santa Clarita, Calif.), following the manufacturer's instructions. Polymerase Chain Reactions (PCR) were conducted to amplify the nrDNA ITS region in a Perkin-Elmer thermocycler using the primers ITS4 (White et al., 1990) and ITS-LEU (see Baum et al., 1998). Each 25- μ l reaction contained 2.5 μ l of Taq polymerase reaction buffer, 4 μ l of dNTP, 0.8 μ l of 50 mM MgCl₂, 1 μ l of each of the two primers (10 μ M), 50–100 ng of genomic DNA, 2 μ l of

TABLE 1. Taxa included in this study.

| SPECIES | AA# | SOURCE | GENBANK ACCESSION # |
|--|----------|--|------------------------|
| <i>Taxus baccata</i> L. | 546–89C | Weilheim-Schongan, Germany | AF259287 |
| <i>T. baccata</i> | 372–35A | Mt. Vitoshka, Bulgaria | AF259294 |
| <i>T. brevifolia</i> Nuttall | 1087–88A | Marion, Oregon, USA | AF259295 |
| <i>T. canadensis</i> Marshall | 601–58A | Ontario, Canada | AF259296 |
| <i>T. canadensis</i> | 1539–82C | West Roxbury, Massachusetts, U.S.A. | AF259298 |
| <i>T. chinensis</i> (Pilger) Rehder | 1395–60A | Hunnewell Pinetum, Massachusetts, U.S.A. (cultivated) | AF259292 |
| <i>T. chinensis</i> var. <i>mairei</i> (Lemee et Levl.) Cheng et Fu | 333–81A | Hangzhou Botanical Garden, China (cultivated) | AF259291 |
| <i>T. cuspidata</i> Sieb. et. Zucc | 17404C | Japan | AF259289 |
| <i>T. cuspidata</i> | 17404D | Japan | AF259290 |
| <i>T. floridana</i> Nuttall ex Chapman | 1178–89A | Liberty County, Florida, U.S.A. | AF259286 |
| <i>T. globosa</i> Schlechtendal | 905–90A | Nuevo León, Mexico | AF259299 |
| <i>T. x hunnewelliana</i> Rehder | 10760B | Hunnewell Pinetum, Massachusetts, U.S.A. (cultivated) | AF259288 |
| <i>T. x media</i> Rehder | 11267–A | Hunnewell Pinetum, Massachusetts, U.S.A. (cultivated) | AF259297 |
| <i>T. wallichiana</i> Zucc. | 141–88A | Pinetum, Blijdenst (cultivated) | AF259293 |
| <i>Pseudotaxus chienii</i> (Cheng) Cheng | 401–95 | Central China | AF259300 |

NOTE: AA stands for the Arnold Arboretum collections. Voucher specimens are deposited in A.

DMSO, 1 unit of Taq polymerase, and sterilized distilled water. The thermocycler program included 94°C for 2 minutes, 30 cycles of PCR reactions, each with a 30-second denature at 94°C, 60-second annealing at 50°C, and 90-second extension at 72°C. An additional 7-minute extension was performed after the PCR cycles. We conducted electrophoresis of the PCR products in a 1% agarose gel to check for the presence of a single band. The Qiagen PCR purification kit was used to clean PCR products (Santa Clarita, Calif.) for direct cycle sequencing, as described elsewhere (Li et al., 1999).

Sequence Editing and Phylogenetic Analysis

For each sample, the ITS region was sequenced using three primers, ITS4, ITS-LEU, and 5.8Sgym (Liston et al., 1996). Sequences were read using an ABI 377 Automated Sequencer (Applied Biosystems, La Jolla, Calif.) and were then edited using Sequencher 3.0 (Gene Codes Corp., Ann Arbor, Mich.). The edited sequences were imported

into PAUP* (version 4.0b4a; Swofford, 2000) and were aligned by eye. The delimitation of ITS-1, 5.8S, and ITS-2 was determined by comparing published sequences in the GenBank (#U77958). *Pseudotaxus chienii*, which appears to be the sister species of *Taxus* (Cheng et al., 2000; Wang and Shu, 2000), was included in parsimony analyses for rooting purposes. All characters were weighted equally, and character states were treated as unordered. Gaps were treated as the fifth character state. Parsimony analyses were carried out using heuristic tree searches in PAUP;* search options included TBR branch swapping, simple sequence addition, MULPARS on, and steepest descent off. To evaluate branch support, we conducted 100 replicates of bootstrap analysis (Felsenstein, 1985) and obtained decay indices (Bremer, 1988; Donoghue et al., 1992).

Estimate of Divergence Time

Maximum likelihood ratio (MLR) tests were conducted using PAUP;* following Baum et al.

(1998), to determine whether a molecular clock could be rejected. For these analyses we used a reduced dataset, with just one sequence for each species, so as to minimize the occurrence of polytomies. Several models were applied, including F81, F84, and HKY (see Baum et al., 1998). The fossil record of *Taxus* and *Pseudotaxus* allowed us to calibrate a base substitution rate. Fossils of *Taxus* date back to the middle Jurassic, and *Pseudotaxus* has been recorded from the late Cretaceous (Florin, 1963). We presume that the two lineages diverged at least by the middle Jurassic (~165 mya).

RESULTS

Sequence Characteristics

We were able to obtain sequences of the entire ITS region of *Taxus* and *Pseudotaxus* using the three sequencing primers. The sequences have been submitted to GenBank (Table 1) and the data matrix and trees are available in TreeBASE (<http://www.harvard.edu/treebase>). The length of the ITS region ranged from 1127 to 1129 base pairs (bp) in *Taxus* and was 1108 bp in *Pseudotaxus*. The length of 5.8S in all sequences was 145 bp, and that of ITS-2 was 205 bp in all species except *T. canadensis*, which was one bp shorter. Most length variation of the ITS region was found in ITS-1, which was from 777 to 779 bp long in *Taxus* and 760 bp in *Pseudotaxus*. The alignment resulted in a data set of 1147 characters, including 29 gaps, 26 of which were between *Taxus* and *Pseudotaxus*. Of the 1147 sites, 252 were variable and 37 were parsimony informative. Sequence divergence was about 19% between *Taxus* and *Pseudotaxus*. Among samples of *Taxus*, sequence divergences were much lower, ranging from 0% to 1.87%, with an average of 0.97% (Table 2). There was little intraspecific variation in the ITS sequences (<0.09%). The G+C content averaged 59% over all of the species, with little variance among sequences; the average G+C content was 51% in 5.8S, 59% in ITS-2, and 61% in ITS-1.

Phylogenetic Relationships

Parsimony analysis generated four trees of 307 steps (CI = 0.96; RI = 0.81); Fig. 2 shows one of the four trees. The other three trees differed from Fig. 2 in either the unresolved E clade or the partially resolved H clade, where *T. × media* was sister to a polytomy of other three accessions of *T. baccata*. Three North American species form a well-supported clade (labeled B

in Fig. 2; bootstrap = 85%, decay = 2), with *T. brevifolia* sister to a C clade containing *T. floridana* and *T. globosa*. The D clade, containing the Old World species and *T. canadensis* of the New World, is weakly supported (bootstrap = 53%, decay = 1). Relationships among three lineages within the D clade are unresolved in the strict consensus tree of the four trees. *Taxus chinensis* and *T. mairei* form a clade (F) with weak support (bootstrap = 68%, decay = 1). The two samples of *T. canadensis* are strongly united (bootstrap = 98%, decay = 4). The G clade, containing *T. cuspidata* and *T. baccata* (H; bootstrap = 94%, decay = 2) is weakly supported (bootstrap = 60%, decay = 1).

Estimated Divergence Time

MLR tests using different evolutionary models did not reject the null hypothesis of clock-like evolution (all $P > 0.2$). On the basis of sequence divergence (ca. 19%) and fossil evidence for the divergence of *Taxus* and *Pseudotaxus* by at least 165 mya, we estimated a rate of change of 5.76×10^{-10} base substitutions per site per year. Based on this rate, the estimated times of divergence for the clades were 9.2–16.15 (A), 6.16–6.94 (B), 0.78 (C), 4.6–10.76 (D), 6.94–10.76 (E), 7.7 (F), and 3.13–4.6 (G) mya, respectively (Fig. 2).

DISCUSSION

Sequence Length Variation

In angiosperms, the ITS region, including the 5.8S gene, is often about 700 bp long (Baldwin et al., 1995). In other seed plants, in contrast, the ITS region varies greatly, from about 1000 bp to several thousand bp (Liston et al., 1996, 1999). Nevertheless, as in some conifers (Liston et al., 1996; Klein et al., unpubl.), the length of the ITS region within *Taxus* varies only within a small range—from 1127 to 1129 bp. In conifers, the ITS-1 region is several times longer than the ITS-2 region (Klein and Li, unpubl.); in *Taxus*, ITS-1 sequences are about four times longer than ITS-2.

Phylogenetic Relationships

Interspecific relationships within *Taxus* have been implied in various taxonomic treatments. Silba (1984) treated *T. floridana* as a variety of *T. canadensis*, suggesting a close relationship between these two species. In the ITS phylogenetic tree, however, *T. canadensis* did not fall into the B clade; instead it is weakly allied with the Old World species (Fig. 2). A similar

TABLE 2. Pairwise sequence distance of species in this study calculated using PAUP* (p x 100).

| SPECIES | 1 | 2 | 3 | 4 | 5 | 6 | 7 | 8 | 9 | 10 | 11 | 12 | 13 | 14 | 15 |
|---------------------------------------|-------|-------|-------|-------|-------|-------|-------|-------|-------|-------|-------|-------|-------|-------|----|
| 1. <i>Taxus baccata</i> 546-89C | - | | | | | | | | | | | | | | |
| 2. <i>T. baccata</i> 372-35A | 0.09 | - | | | | | | | | | | | | | |
| 3. <i>T. brevifolia</i> 1087-88A | 1.42 | 1.51 | - | | | | | | | | | | | | |
| 4. <i>T. canadensis</i> 601-58A | 0.89 | 0.98 | 1.42 | - | | | | | | | | | | | |
| 5. <i>T. canadensis</i> 1539-82C | 0.98 | 1.07 | 1.51 | 0.09 | - | | | | | | | | | | |
| 6. <i>T. chinensis</i> 1395-60A | 1.15 | 1.24 | 1.69 | 1.15 | 1.24 | - | | | | | | | | | |
| 7. <i>T. mairei</i> 333-81A | 1.15 | 1.24 | 1.51 | 1.15 | 1.24 | 0.89 | - | | | | | | | | |
| 8. <i>T. cuspidata</i> 17404C | 0.44 | 0.53 | 1.15 | 0.62 | 0.71 | 0.89 | 0.89 | - | | | | | | | |
| 9. <i>T. cuspidata</i> 17404D | 0.36 | 0.44 | 1.06 | 0.53 | 0.62 | 0.80 | 0.80 | 0.09 | - | | | | | | |
| 10. <i>T. floridana</i> 1178-89A | 1.60 | 1.69 | 0.71 | 1.60 | 1.69 | 1.86 | 1.69 | 1.33 | 1.24 | - | | | | | |
| 11. <i>T. globosa</i> 905-90A | 1.60 | 1.69 | 0.80 | 1.60 | 1.69 | 1.87 | 1.69 | 1.33 | 1.24 | 0.09 | - | | | | |
| 12. <i>T. hunnewelliana</i> 10760B | 0.53 | 0.62 | 1.24 | 0.71 | 0.80 | 0.98 | 0.98 | 0.27 | 0.18 | 1.42 | 1.42 | - | | | |
| 13. <i>T. media</i> 11267-A | 0.00 | 0.09 | 1.24 | 0.71 | 0.80 | 0.98 | 0.98 | 0.27 | 0.18 | 1.42 | 1.42 | 0.36 | - | | |
| 14. <i>T. baccata</i> 141-81A | 0.00 | 0.09 | 1.42 | 0.89 | 0.98 | 1.15 | 1.15 | 0.44 | 0.36 | 1.60 | 1.60 | 0.53 | 0.00 | - | |
| 15. <i>Pseudotsuga chienii</i> 401-95 | 19.00 | 18.91 | 19.01 | 18.81 | 18.82 | 18.91 | 18.81 | 18.63 | 18.72 | 18.91 | 18.88 | 18.90 | 18.83 | 19.00 | - |

NOTE: Species names are followed by the accession numbers of the Arnold Arboretum

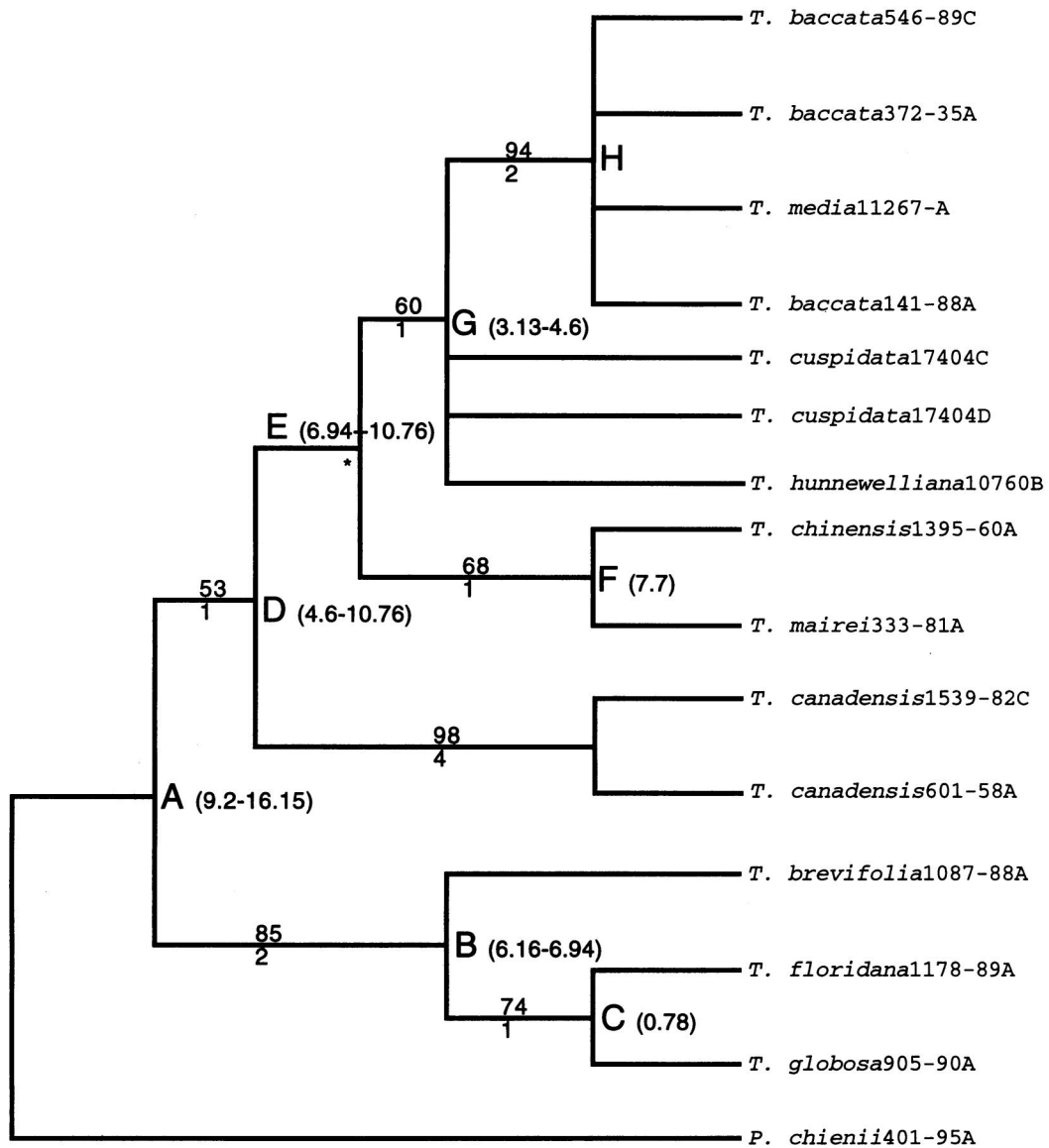

FIGURE 2. One of four parsimonious trees of 307 steps (CI = 0.96, RI = 0.81). The asterisk indicates the clade not present in the strict consensus tree. Numbers above and below branches are bootstrap percentages and decay values respectively. Letters A through H mark clades discussed in the text. Numbers in parentheses indicate the estimated times of divergence.

relationship has been recently suggested by a study of stomatal structure in *Taxus* (Spjut, 2000). Forcing *T. canadensis* into a clade with *T. floridana* requires two extra steps. Additional data are needed to test this novel hypothesis.

Taxus chinensis has been treated as a variety of either *T. wallichiana* (Florin, 1948), *T. baccata* (Henry, 1906), or *T. cuspidata* (Pilger, 1903; Schneider, 1913). In our ITS trees, *T. baccata*

and *T. cuspidata* form a weakly supported clade (G), with *T. chinensis* more distantly related.

Taxus maireri has been considered a variety of either *T. chinensis* (Cheng and Fu, 1978) or *T. wallichiana* (Li and Fu, 1997). In our ITS trees, *T. maireri* and *T. chinensis* form a clade. *Taxus wallichiana* was not available for this study.

Rehder (1925) described *Taxus* × *hunnewelliana* as a probable hybrid between *T. canadensis*

and *T. cuspidata*. In this study we sampled one of the living specimens Rehder used in the original description of this putative hybrid (Arnold Arboretum accession #10760B). We did not find polymorphic sites indicative of hybridization between *T. canadensis* and *T. cuspidata*, and this sample clustered with *T. cuspidata*, separate from *T. canadensis*.

Biogeographic Implications

We found low within-species sequence divergences (<0.09%), and with only one exception, divergences between species are at least twice as great as within species (Table 2). Low sequence divergence between *T. floridana*, from Florida, and *T. globosa*, from Mexico and Central America, suggests very recent separation between the lineages in these regions and is consistent with treating these populations as belonging to the same species. Disjunctions between eastern North America and eastern Mexico are well known (e.g., *Liquidambar* and *Viburnum*; see Burnham and Graham, 1999), and in at least some of these cases, levels of sequence divergence are also low (e.g., *Hamamelis* [Li et al., 2000] and *Cercis* [Davis et al., unpubl. data]). Further study of such cases may indicate recent vicariance events

simultaneously affecting a number of lineages.

Curiously, *Taxus floridana* and *T. globosa* appear not to be directly related to the eastern North American species, *T. canadensis*. Instead, these species are united quite strongly with the western North American *T. brevifolia*. If the rooting of our trees is correct, the four New World species do not form a clade, and *T. canadensis* is actually more closely related to Old World species. Unfortunately, the exact relationships of *T. canadensis* remain unresolved. It is possible, on the basis of our analyses, that *T. canadensis* is most closely related to Asian species. In contrast, a direct connection to the European species, *T. baccata*, seems less likely.

Taxus has a rich and deep fossil history (Florin, 1963). If our age estimates are at all accurate, the modern species of *Taxus* stem from a rather recent common ancestor. In view of the apparent great age of *Taxus*, our results suggest either a long period of stasis prior to the radiation that resulted in the modern species, or perhaps earlier periods of diversification followed by the extinction of lineages. Until *Taxus* fossils can be incorporated in phylogenetic analyses, their bearings on these hypotheses will be difficult to interpret.

LITERATURE CITED

- BALDWIN, B. G., M. J. SANDERSON, J. M. PORTER, M. F. WOJCIECHOWSKI, C. S. CAMPBELL, AND M. J. DONOGHUE. 1995. The ITS region of nuclear ribosomal DNA: A valuable source of evidence on angiosperm phylogeny. *Ann. Missouri Bot. Gard.* 82: 247–277.
- BAUM, D. A., R. L. SMALL, AND J. F. WENDEL. 1998. Biogeography and floral evolution of Baobabs (*Adansonia*, Bombacaceae) as inferred from multiple data sets. *Syst. Biol.* 47: 181–207.
- BOLSINGER, C. L., AND A. E. JARAMILLO. 1990. *Taxus brevifolia* Nutt. Pacific Yew. Pages 573–579 in R. M. BURNS AND B. H. HONKALA, *Silvics of North America*. Vol. 1. USDA Forest Survey Handbook. Forest Service, United States Department of Agriculture, Washington, D.C.
- BREMER, K. 1988. The limits of amino acid sequence data in angiosperm phylogenetic reconstruction. *Evolution* 42: 795–803.
- BURNHAM, R. J., AND A. GRAHAM. 1999. The history of neotropical vegetation: New developments and status. *Ann. Missouri Bot. Gard.* 86: 546–589.
- CHENG, I., R. G. NICOLSON, K. TRIPP, AND S. M. CHAW. 2000. Phylogeny of Taxaceae and Cephalotaxaceae inferred from chloroplast *matK* and nuclear rDNA ITS region. *Molec. Phylog. Evol.* 14: 353–365.
- CHENG, W. C., AND L. K. FU. 1978. *Taxaceae. Fl. Reipubl. Popularis Sin.* 7: 439–467.
- DONOGHUE, M. J., R. G. OLMSTEAD, J. F. SMITH, AND J. D. PALMER. 1992. Phylogenetic relationships of Dipsacales based on *rbcL* sequences. *Ann. Missouri Bot. Gard.* 79: 333–345.
- FARJON, A. 1998. *World Checklist and Bibliography of Conifers*. Royal Botanical Gardens, Kew.
- FELSENSTEIN, J. 1985. Confidence limits on phylogenies: An approach using the bootstrap. *Evolution* 39: 783–791.
- FLORIN, R. 1948. On the morphology and relationships of the Taxaceae. *Bot. Gaz.* 110: 31–39.
- . 1963. The distribution of conifers and taxod genera in time and space. *Acta Horti. Berg.* 20: 121–312.
- GERNANDT, D. S., AND A. LISTON. 1999. Internal transcribed spacer region evolution in *Larix* and *Pseudotsuga* (Pinaceae). *Amer. J. Bot.* 86: 711–723.
- HART, J. A. 1987. A cladistic analysis of conifers: Preliminary results. *J. Arnold Arb.* 68: 296–307.
- HARTZELL, H., JR. 1991. *The Yew Tree, A Thousand Whispers*. Hulogosi, Eugene, Ore.
- HENRY, J. E. 1906. *Taxus* Pages 98–126 in J. E. HENRY AND A. HENRY, EDs., *The Trees of Great Britain and Ireland*. Vol. 1. Private printing, Edinburgh.

- JUDD, W. S., C. S. CAMPBELL, E. A. KELLOGG, AND P. F. STEVENS. 1999. *Plant Systematics, a Phylogenetic Approach*. Sinauer Associates, Sunderland, Mass.
- KIM, Y.-D., AND S.-H. KIM. 1999. Phylogeny of *Weigela* and *Diervilla* (Caprifoliaceae) based on nuclear rDNA ITS sequences: Biogeographic and taxonomic implications. *J. Plant Res.* 112: 331–341.
- Krüßmann, G. 1985. *Manual of Cultivated Conifers* Volume 2. Timber Press, Portland, Oregon.
- LI, J., A. L. BOGLE, AND A. S. KLEIN. 1999. Phylogenetic relationships of the Hamamelidaceae inferred from sequences of internal transcribed spacers (ITS) of nuclear ribosomal DNA. *Amer. J. Bot.* 86: 1027–1037.
- , ———, ———, AND M. J. DONOGHUE. 2000. Phylogeny and biogeography of Hamamelis (Hamamelidaceae). *Harv. Pap. Bot.* 5: 171–178.
- LI, N., AND L. K. FU. 1997. Notes on gymnosperms I: Taxonomic treatments of some Chinese conifers. *Taxon* 7: 261–264.
- LISTON, A., W. A. ROBINSON, AND J. M. OLIPHANT. 1996. Length variation in the nuclear ribosomal DNA internal transcribed spacer region of non-flowering seed plants. *Syst. Bot.* 21: 109–120.
- , W. A. ROBINSON, D. PINERO, AND E. R. ALVAREZ-BULLYA. 1999. Phylogenetics of *Pinus* (Pinaceae) based on nuclear ribosomal DNA internal transcribed spacer region sequences. *Mol. Phyl. Evol.* 11: 95–109.
- PILGER, R. 1903. Taxaceae. Pages 110–117 in R. ENGLER, *Pflanzenreich*. IV 5. W. Engelmann, Leipzig.
- PRICE, R. A. 1990. The genera of Taxaceae in the southeastern United States. *J. Arnold Arb.* 71: 69–91.
- REHDER, A. 1925. New species, varieties, and combinations from the herbarium and the collections of the Arnold Arboretum. *J. Arnold Arb.* 6: 201–208.
- SCHNEIDER, C. 1913. *Silva Tarouca, Unsere Freiland-Nadelholzer*. Pages 274–278. Leipzig.
- SILBA, J. 1984. An international census of the Coniferae, I. *Phytologia Mem.* 7: 1–79.
- SPJUT, R. W. 2000. The morphological relationships of *Taxus canadensis* (Taxaceae) in North America and Eurasia. *Amer. J. Bot.* 87 (6, suppl.). 159. (Abstract)
- SWOFFORD, D. L. 2000. PAUP.* Phylogenetic analysis using parsimony (and other methods). Version 4.0b4a. Sinauer, Sunderland, Mass.
- VOLIOTIS, D. 1986. Historical and environmental significance of the Yew (*Taxus baccata* L.). *Israel J. Bot.* 35: 47–52.
- WANG, X.-Q., AND Y.-Q. SHU. 2000. Chloroplast *matK* gene phylogeny of Taxaceae and Cephalotaxaceae, with additional reference to the systematic position of *Nageia*. *Act. Phytotax. Sin.* 38: 201–210.
- WANI, M. C., H. L. TAYLOR, M. E. WALL, P. COGGON, AND A. T. MCPHAIL. 1971. Plant antitumor agents: VI. The isolation and structure of taxol, a novel antileukemic and antitumor agent from *Taxus brevifolia*. *J. Amer. Chem. Soc.* 93: 2325–2327.
- WELCH, H., AND G. HADDOW. 1993. *The World Checklist of Conifers*. Landsman's Bookshop Ltd., Herefordshire.
- WHITE, T. J., T. BRUNS, S. LEE, AND J. TAYLOR. 1990. Amplification and direct sequencing of fungal ribosomal RNA genes for phylogenetics. Pages 315–322 in M. INNIS, D. GELFAND, J. SNINSKY AND T. WHITE, EDS., *PCR Protocols: A Guide to Methods and Applications*. Academic Press, San Diego.